



Indicator light box

FJHL Model

Description

The indicator light box is used to indicate the presence of power along the electrical tracing. This product allows the user to maintain a complete visual of his thermal system, facilitating supervision and monitoring.

Technical specifications

- FJHL Model
- Voltage input 220v – 380v
- Amps 40 A
- IP54 protection
- Nivel EX: ExdemIIBT4Gb
- DMC casing

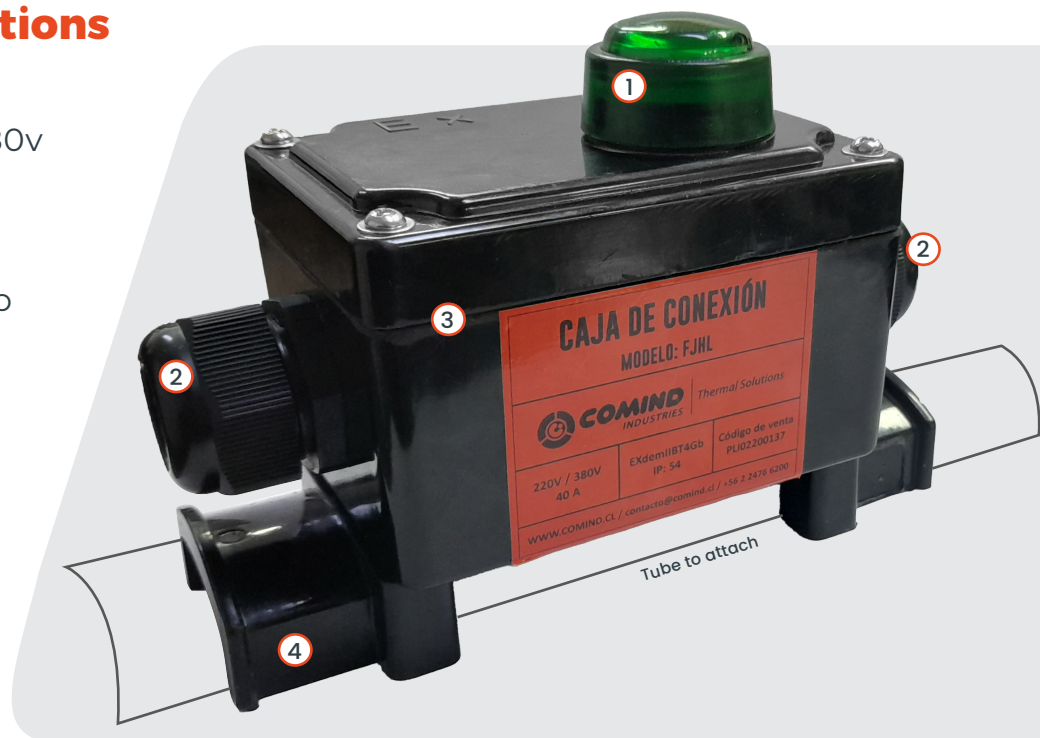

Scan me

Kit content

N °	Parts
1	Indicator light
2	Power cord entry
3	Container
4	Base

Dimensions

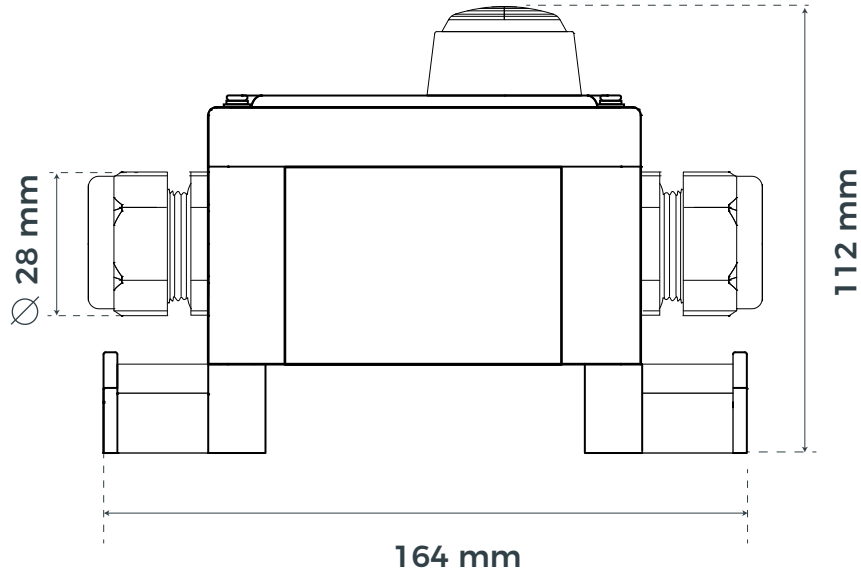

Front view

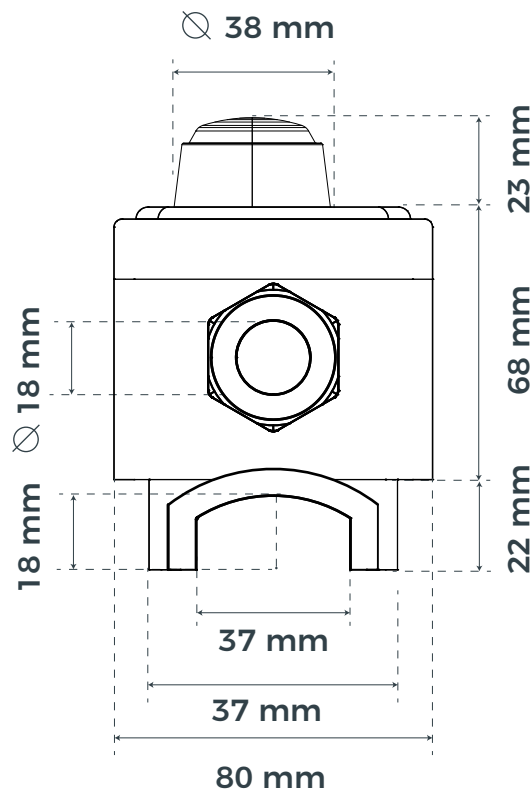

Side view