



END SEAL LAMP

EAS model

Description

Our End Seal Lamp indicates the operating status of a heat trace system. It helps in-process inspection and subsequent maintenance to operate efficiently.



Scan me

Content

N°	Part
1	LED light
2	Lamp holder
3	Insulated terminals
4	Clamping bracket
5	Light Protection



Technical specifications

Model	Nominal voltage	Minimum installation T °	Ambient T ° range	Maximum pipe temperature	IP Level
EAS	AC 110 V - 277 V	-30° C	-40 a +55°C	+180° C	IP 65

Dimensions

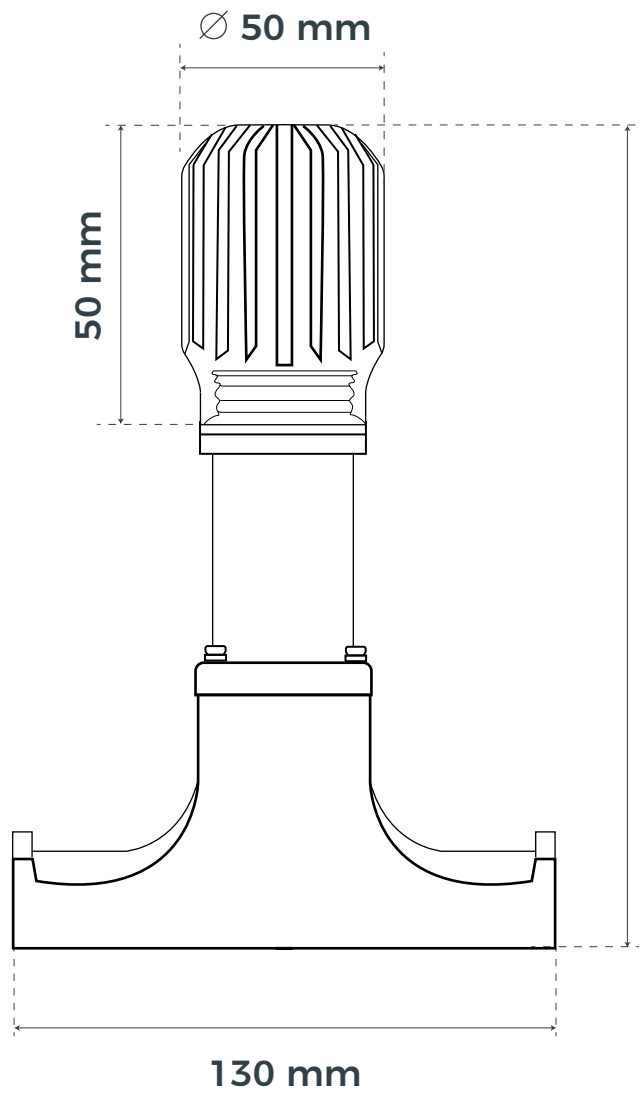

Front view

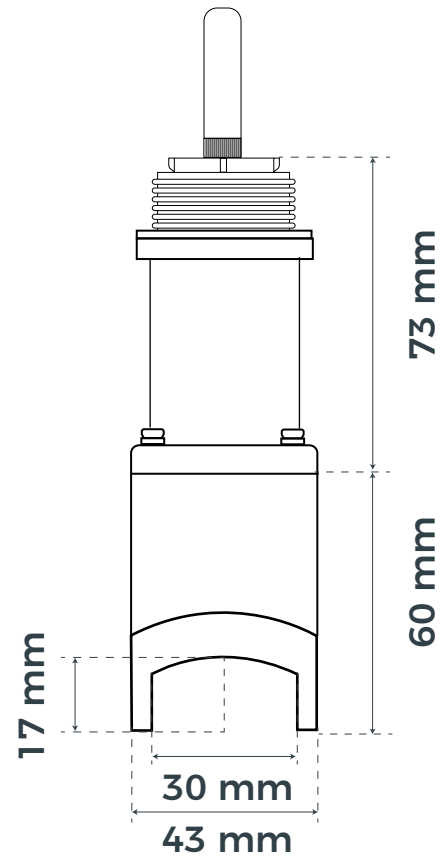

Side view
no screen