



# User Manual YOMOGA **BOX**

# Installation

## Yomoga Box

01

Strip the outer jacket (140mm) from the end of the heating cable. (Do not damage braiding.)

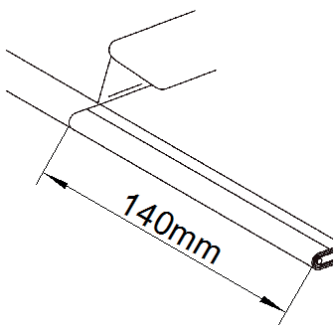

02

Create an opening on the braiding with a screwdriver, through which the heating cable can pass.

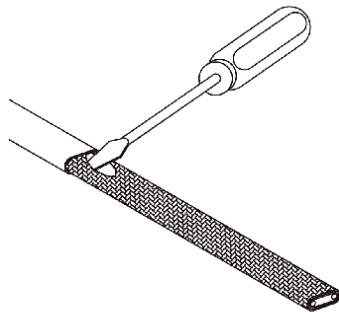

03

Lightly bend the heating cable, and pull the heating cable out of the opening with a screwdriver. Then sort the braiding into a strand.

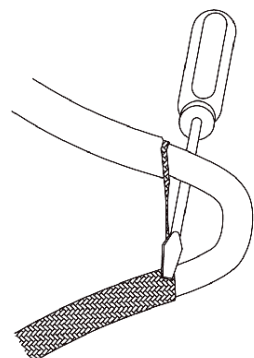

04

Remove the insulation (120mm) from the end.

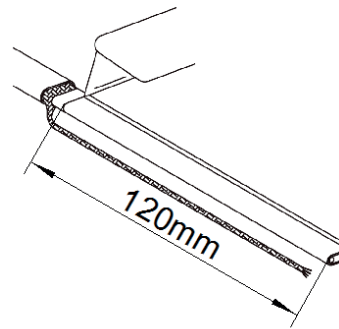

05

Remove the PTC layer, do not damage the bus wires.

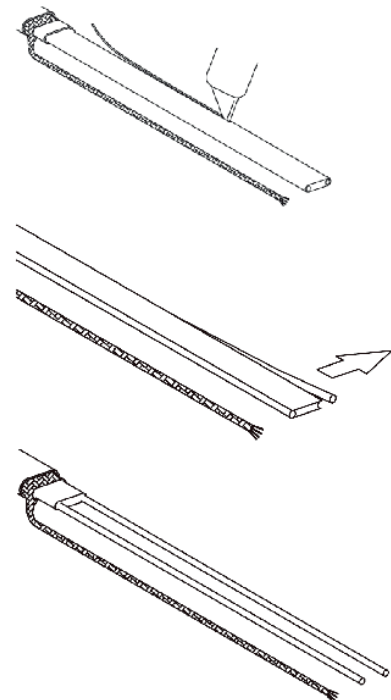

# Installation

## Yomoga Box

06

Run the heating cable through either channel of the base of standoff and insert a grommet on the heating cable till it meets the outer jacket layer. Another hole should be stuffed with a rubber plug.

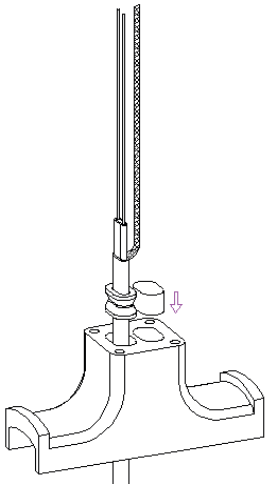

08

Adjust the position of the heating cable, make sure that it comes out from the top of standoff at least 100mm. Insert the grommet into the channel on the base of standoff and screw the upper and base of the standoff. Then fix T-Standoff on the pipe with clamps.

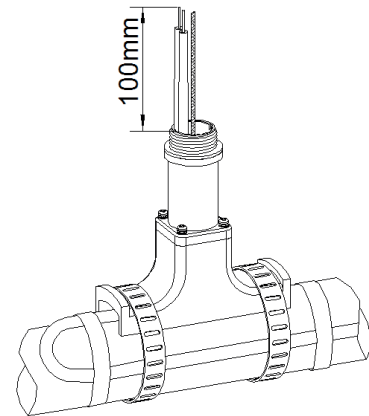

07

Have the cable run through the upper of standoff. Then insert both conductors into the forked tube. The insulation layer of heating cable should be wrapped well by the forked tube.

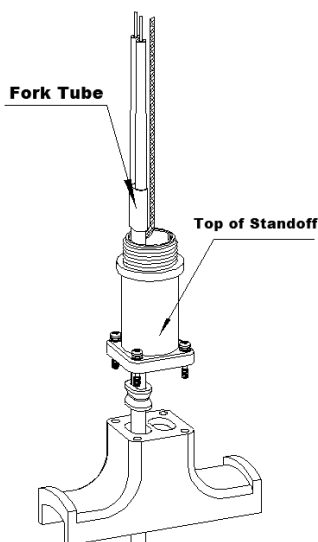

09

Put the seal ring and junction box on the upper of the standoff accordingly, then fix the junction box and standoff with a locknut as shown in diagram 9.

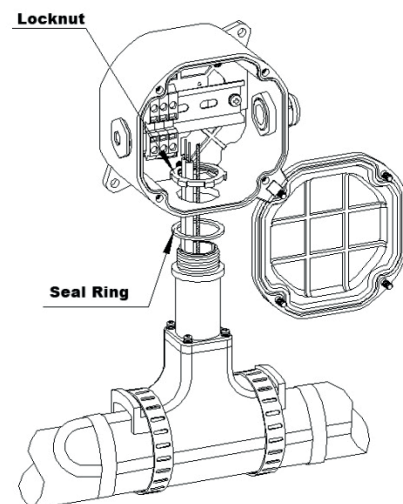

# Instalación

## Yomoga Box

10

Strip the insulation of the power wires 13mm. Have the power cable go into junction box, then stuff the entrance by screwing the device.

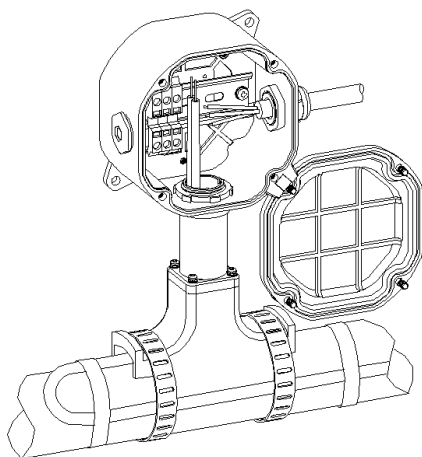

12

Confirm the installation is correct and all the cables are fixed. Close the lid of the EPJB junction box and lock it with socket head cap screws.

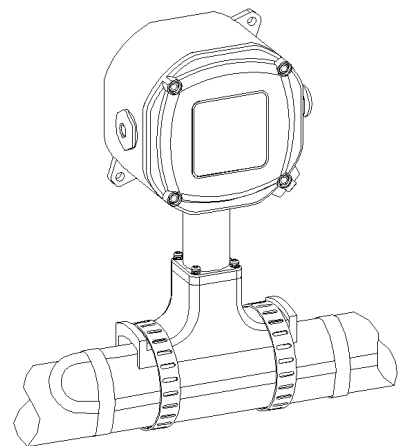

11

Open the terminal clip by levering the spring with a slotted screwdriver. Put the power wires, heating cable conductors, and braiding into terminal clips. (Please refer to the diagram for more information.)

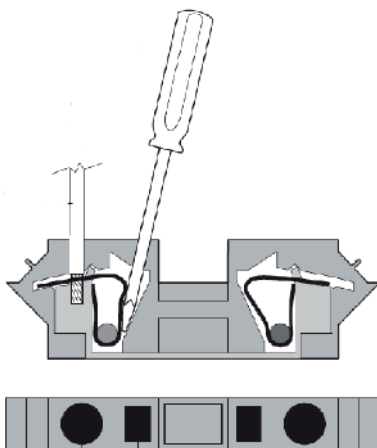

# Connection Diagram

